

NOTE: OPTICAL PATH INCLUDES 2MM AR COATED CHAMBER WINDOW AND 0.7MM CCD COVER GLASS

SURFACE RECESSED INTO CAMERA COVER

	UNLESS OTHERWISE SPECIFIED:	NAME	DATE	Quantum Scientific Imaging, Inc. TITLE: 500 Series Customer Reference
	DIMENSIONS ARE IN INCHES TOLERANCES: FRACTIONAL \pm N/A ANGULAR: MACH $\pm 0^\circ 30'$ TWO PLACE DECIMAL ± 0.01 THREE PLACE DECIMAL ± 0.005	DRAWN	D. Challis	
PROPRIETARY AND CONFIDENTIAL THE INFORMATION CONTAINED IN THIS DRAWING IS THE SOLE PROPERTY OF QUANTUM SCIENTIFIC IMAGING, INC. ANY REPRODUCTION IN PART OR AS A WHOLE WITHOUT THE WRITTEN PERMISSION OF QUANTUM SCIENTIFIC IMAGING, INC. IS PROHIBITED.	INTERPRET GEOMETRIC TOLERANCING PER: ASME Y14.5M	ENGINEER	N. Barry	SIZE B DWG. NO. D05000600 REV F4
	MATERIAL	MFG APPR.		
	FINISH	Q.A.	COMMENTS:	
		FILENAME: 500 Series Customer Reference		

WSG MODEL
CONTROLLING DIMENSIONS IN INCHES
[MM] SHOWN FOR REFERENCE

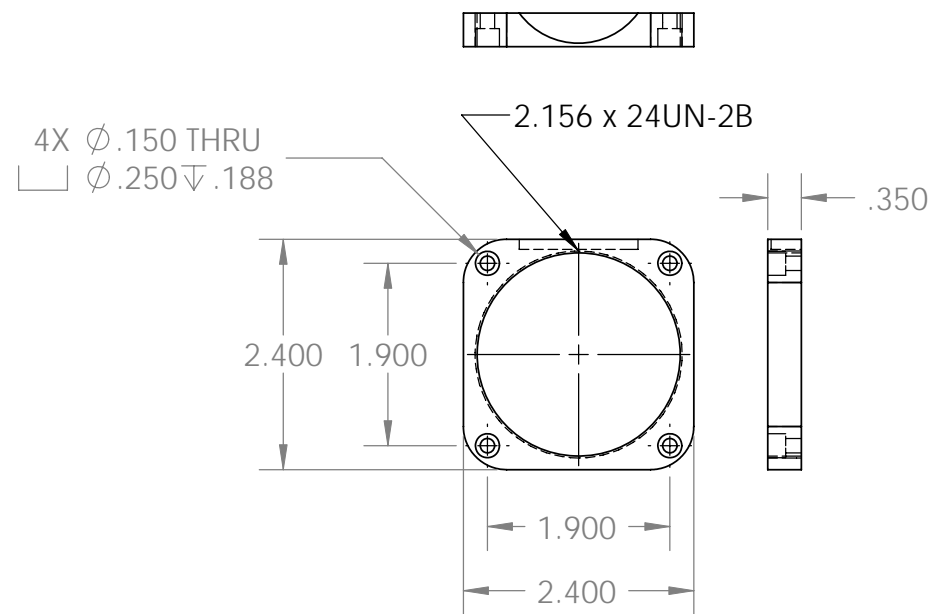

2.156 ADAPTER
SEE SHEET 1
FOR OTHER ADAPTERS

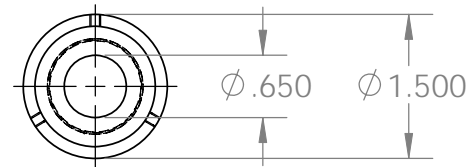
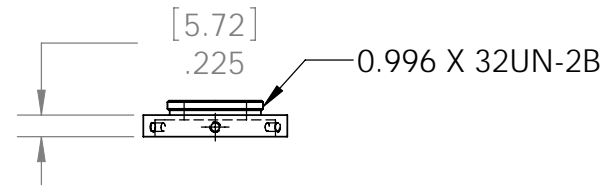

CS-MOUNT
ADAPTER

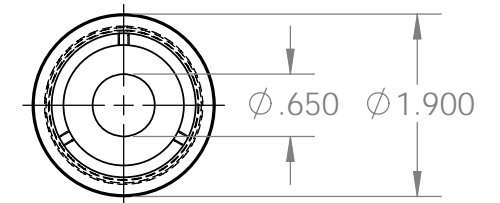
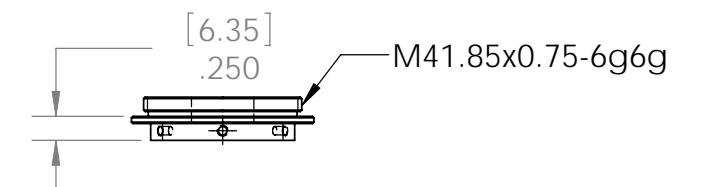

T-MOUNT
ADAPTER

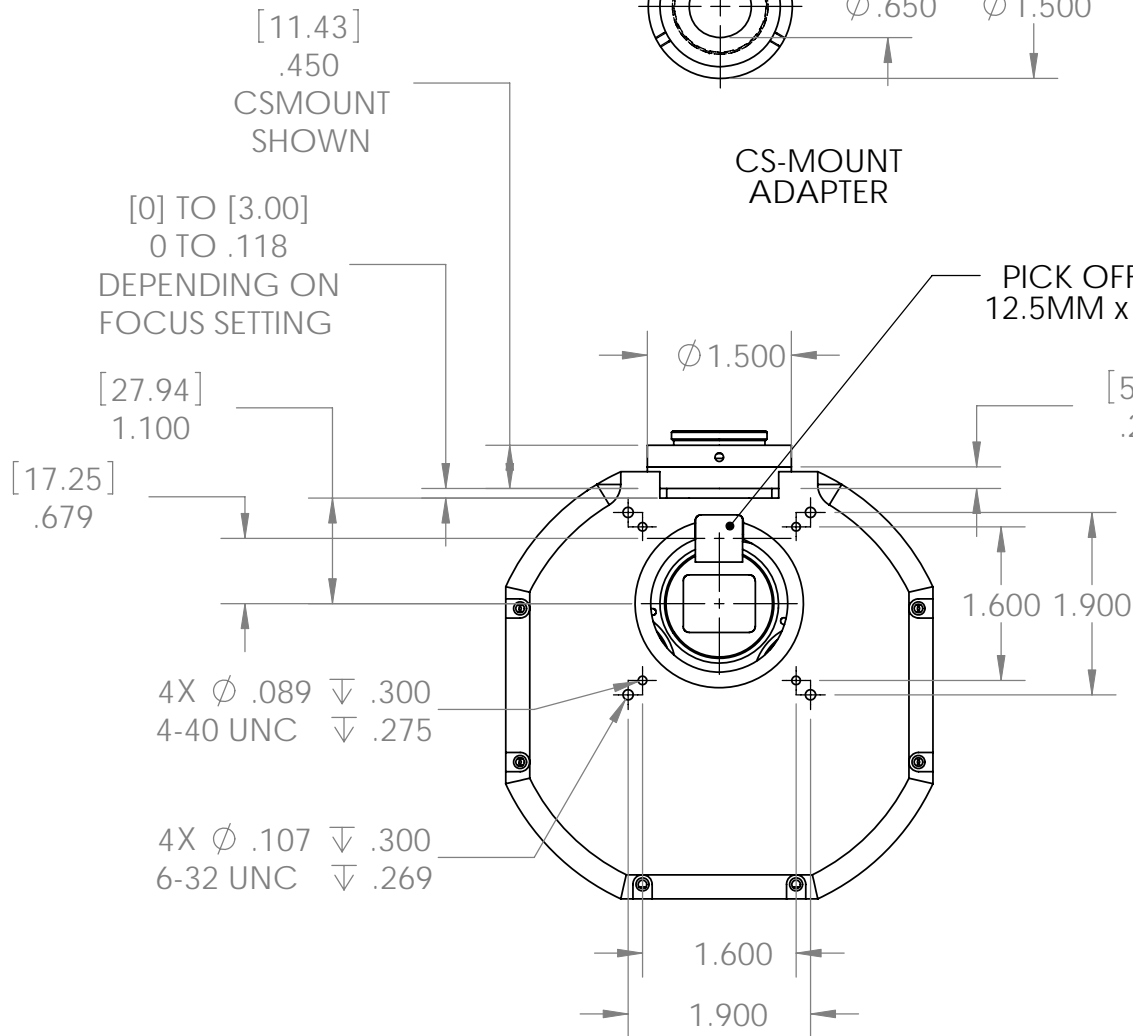

[17.53]
.690
FILTER SEAT

[20.70]
.815
TOP OF WHEEL
(FILTER MAY EXCEED THIS HEIGHT)

THIRD ANGLE PROJECTION

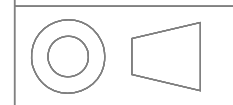

PROPRIETARY AND CONFIDENTIAL
THE INFORMATION CONTAINED IN THIS DRAWING IS THE SOLE PROPERTY OF QUANTUM SCIENTIFIC IMAGING, INC. ANY REPRODUCTION IN PART OR AS A WHOLE WITHOUT THE WRITTEN PERMISSION OF QUANTUM SCIENTIFIC IMAGING, INC. IS PROHIBITED.

UNLESS OTHERWISE SPECIFIED:

DIMENSIONS ARE IN INCHES
TOLERANCES:
FRACTIONAL ± N/A
ANGULAR: MACH ± 0° 30'
TWO PLACE DECIMAL ± 0.01
THREE PLACE DECIMAL ± 0.005

INTERPRET GEOMETRIC
TOLERANCING PER: ASME Y14.5M

MATERIAL

FINISH

	NAME	DATE
DRAWN	D. Challis	
CHECKED		
ENGINEER		
MFG APPR.		
Q.A.		
COMMENTS:		

FILENAME: 500 Series Customer Reference

Quantum Scientific Imaging, Inc.

TITLE:
500 Series Customer Reference

SIZE **B** DWG. NO. D05000600 REV **F4**

SCALE: 1:2 WEIGHT: SHEET 2 OF 3

8 7 6 5 4 3 2 1

D

D

31MM FILTER RETAINING SCREW
5X ϕ .070 THRU ALL
2-56 UNC THRU ALL

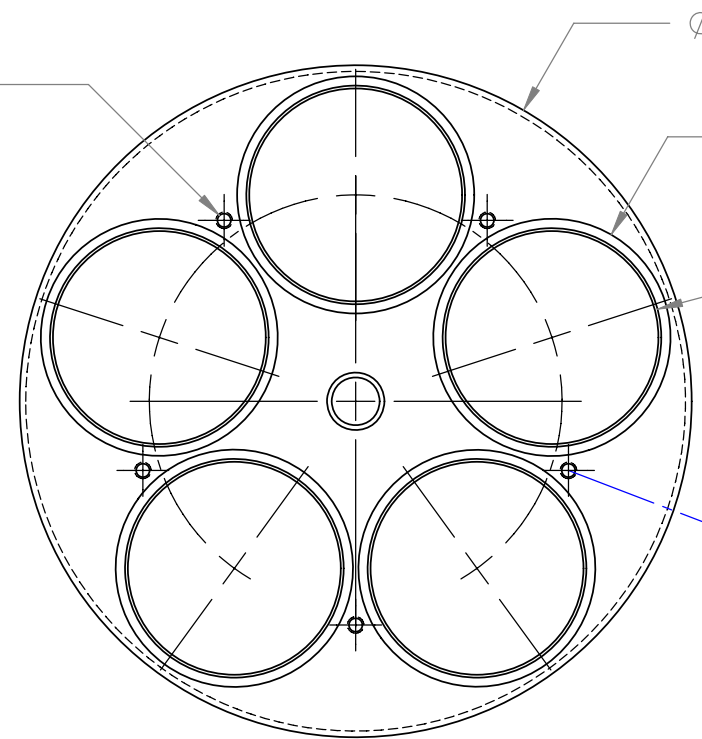

ϕ 3.500

5X ϕ 1.235

5X
 \checkmark ϕ 1.139 X 90°
THREAD
1.1088 MIN PITCH ϕ
1.1310 MAX PITCH ϕ
42 TPI

31MM
5MM THICK
FILTERS



2-56 x 5/16
BUTTON SOCKET



FLAT WASHER



SHOULDER WASHER



NYLON WASHER

31MM
3MM THICK
FILTERS



2-56 x 1/4
BUTTON SOCKET



FLAT WASHER



NYLON WASHER

C

C

B

B

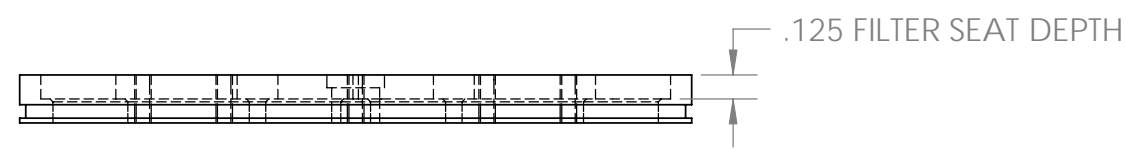

.125 FILTER SEAT DEPTH

A

A

THIRD ANGLE PROJECTION

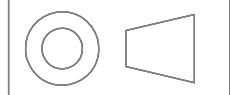

PROPRIETARY AND CONFIDENTIAL
THE INFORMATION CONTAINED IN THIS
DRAWING IS THE SOLE PROPERTY OF
QUANTUM SCIENTIFIC IMAGING, INC.
ANY REPRODUCTION IN PART OR AS A
WHOLE WITHOUT THE WRITTEN
PERMISSION OF QUANTUM SCIENTIFIC
IMAGING, INC. IS PROHIBITED.

UNLESS OTHERWISE SPECIFIED:

DIMENSIONS ARE IN INCHES
TOLERANCES:
FRACTIONAL \pm N/A
ANGULAR: MACH \pm 0° 30'
TWO PLACE DECIMAL \pm 0.01
THREE PLACE DECIMAL \pm 0.005

INTERPRET GEOMETRIC
TOLERANCING PER: ASME Y14.5M

MATERIAL

FINISH

NAME DATE

DRAWN D. Challis

CHECKED

ENGINEER N. Barry

MFG APPR.

Q.A.

COMMENTS:

FILENAME: 500 Series Customer Reference

Quantum Scientific Imaging, Inc.

TITLE:
500 Series Customer Reference

SIZE
B

DWG. NO.
D05000600

REV
F4

SCALE: 1:1

WEIGHT:

SHEET 3 OF 3

8 7 6 5 4 3 2 1